

DESK.T-KG



Compact

Table Spot welder

EasySetting



For Example Easy to weld nuts

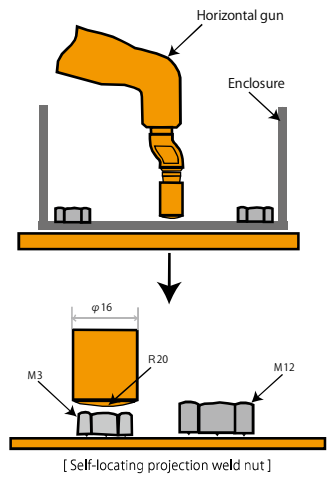

Specifications [NK-71HE-KG-EZ]

- Rated Capacity : 40 k VA Ac380~480V 3φ 50/60Hz
- Gun type : Horizontal
- Maximum current : 12000A
- Electrode force : 2.5kN
- Duty cycle : 7%
- Table size : t 15×400×250mm
- Cooling water : 8.5L/min or more
- Electrode tip : φ13 or φ16 (taper 1/10)
- Machine size : W730×D1170×H1410mm
- Weight : 400kg

Reference of welding capacity : Mild steel (2.3×2.3mm)
Stainless (2.5×2.5mm) Galvanneal steel (2.3×2.3mm)
Galvanized steel (2.3×2.3mm)

*Above mentioned materials are slightly different by manufacturer, or by country in the process of production. Koyo giken Inc. warrants the performance of our product MYSPOT, not warrants those materials and their thickness.

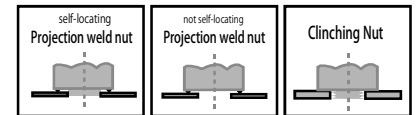

Features

1. Clean and Strong

No burn, no distortion



2. Minimize protrusions

Eliminate grinder finishing and keep the work environment clean.

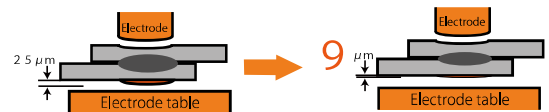

3. Suitable for coated materials

By highly-efficient heat generation



4. Eliminate "sheet separation"

Keep the product as flat as possible



5. **EasySetting** selects the optimum parameters.

By entering the "material" and "thickness".

